



**Vredo** Self-Propelled Trac

**VT7028**

**New!**



**Vredo**

*The proven solution*

**Vredo**

The best in the field

# IN-HOUSE DEVELOPMENT

Vredo is a leading manufacturer of agricultural equipment. Vredo's regular production produces mainly four product lines:

- **Overseeders**
- **Slicing Filters**
- **Slurry Injectors**
- **Self-Propelled Vehicles.**

All these product lines are developed and produced fully in-house. To this end, Vredo is equipped with state of the art production equipment. Vredo sells and distributes her products directly and through a carefully selected distribution network both nationally and internationally.

## History

The beginnings of the company go back to 1947. At that time Mr. B de Vree, a farmer's son, started an agricultural contractors business. The activities were diverse and machines were often adapted to the specific demands of the heavy clay soils of the local Betuwe area.

The adaption of existing machinery changed slowly in the course of time into the development of new machines. The agricultural contracting business changed therefore more and more into an engineering company and later into a fully-fledged factory.

In 1976 de Vree introduced a completely self-developed machine, it was the Vredo Overseeder. At the end of the 80's the same double disc principal was used for the development of the unique Vredo Slurry Injectors.

In 1989 Vredo mounted a slurry tank on top of a Horsch three wheel self-propelled flotation vehicle. This was Vredo's first foray into working with self-propelled vehicles. Since 1994 Vredo has, entirely in-house, engineered and produced more than 400 self-propelled vehicles.

## Vision

Vredo has set itself the objective to contribute to the further development of the industry with her products. It's important to Vredo that all parties concerned, including partners and customers can obtain good financial results by using Vredo products.



The Vredo logo, featuring the word "Vredo" in a stylized, red, cursive font.



# CONTENTS

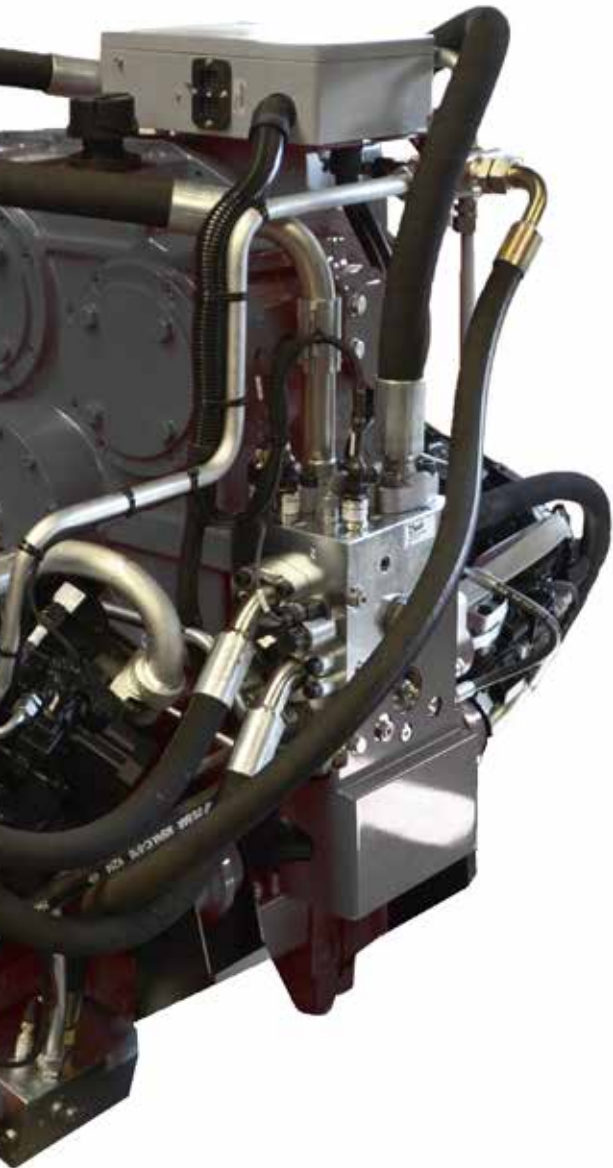

IN-HOUSE DEVELOPMENT	2
INNOVATIVE AND LARGER	4
TRANSMISSION	5
MACHINE CONFIGURATIONS	6-7
THE VT7028 CONCEPT	8-9
POWERTRAIN VT7028	10-11
STEERING & WEIGHT DISTRIBUTION	11-12
OPERATOR'S CAB	12
FEATURES AND OPTIONS	12-13
SPECIFICATIONS	14-15
VREDO SUPPORT/COLOPHON	REAR

## Key features VT7028:

UNIQUE VREDO CVT TRANSMISSION  
VERY LOW FUEL CONSUMPTION  
LOWEST WHEEL WEIGHT  
ALL ROUND SUSPENSION  
HEAVY DUTY AXLES AND BRAKES  
THE NEXT GENERATION TRAC VEHICLE

# INNOVATIVE AND LARGER



The market demand for higher capacity applicators for liquid slurry injecting and dry-manure spreading has resulted in the new Vredo VT7028 Multi-purpose Trac vehicle in both two and three axle configurations.

This new Trac has a midship installed Deutz 16 liter V8 engine with 687 hp together with the all new Vredo VVT700 CVT transmission. The VT7028 enjoys all round suspension, an all wheel steering and heavy duty axles with external disc brakes. The latest generation of agricultural tyres are able to be fitted on this new Trac.

The machine also has a flat loading platform, which is suitable to take all types of implement systems, e.g. slurry tanks, watertanks, spreader boxes, sugarbeet boxes, wood chippers etc. And thanks to the engine and transmission being mounted between the axles the weight distribution is perfect and the center of gravity is kept low.

This is the applicator machine with the lowest weight per tyre in the market. It saves the soil owing to its low ground compaction.

**The new VT7028 and its unique features...  
...the industry spearhead in the application business!**

*Vredo*



# VREDO VARIABLE TRANSMISSION

## Vredo VVT700

Due to the lack of a suitable CVT transmission available in the market for its new Trac, Vredo took the decision to design its new VVT700 transmission entirely in-house. The newly developed Vredo Continuous Variable Transmission, VVT700, is state of the art technology for maximum tractive effort, stepless speed adjustment and lowest fuel consumption in the industry. Combining the unique flexibility of the hydrostatic principle with the high effectiveness of mechanical power transmission, we created a high efficiency and very functional transmission with three pump pads for external hydraulics, a shiftable full power mechanical PTO and continuous all wheel drive with differential locking option.

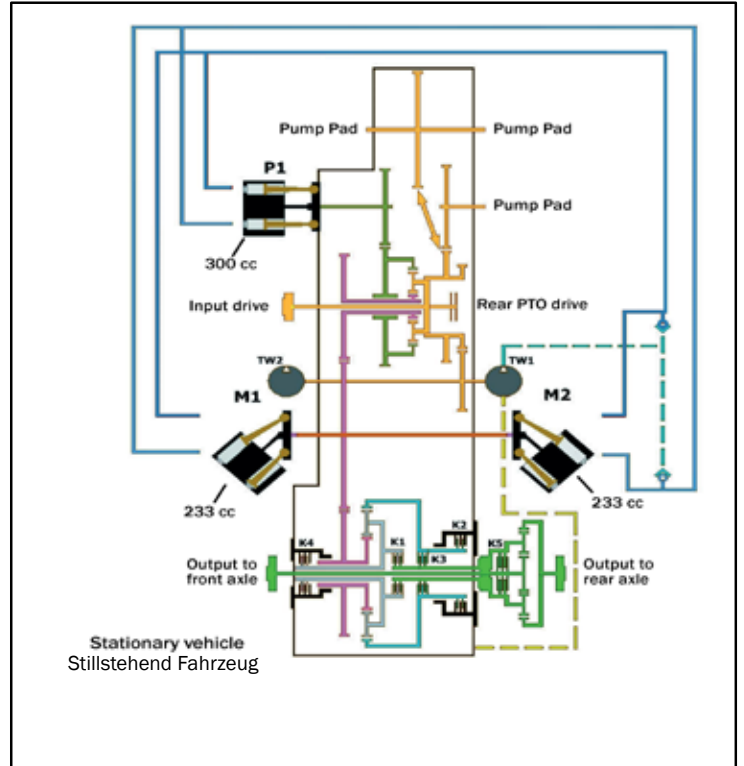
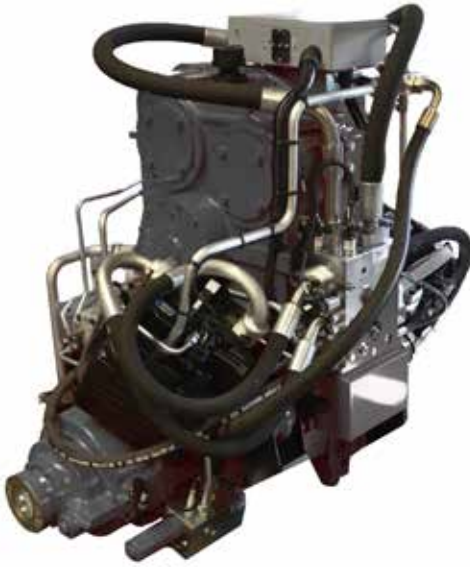

## Tractive force

Tractive Force - Speed Diagramm VT7028 with VVT700 Transmission

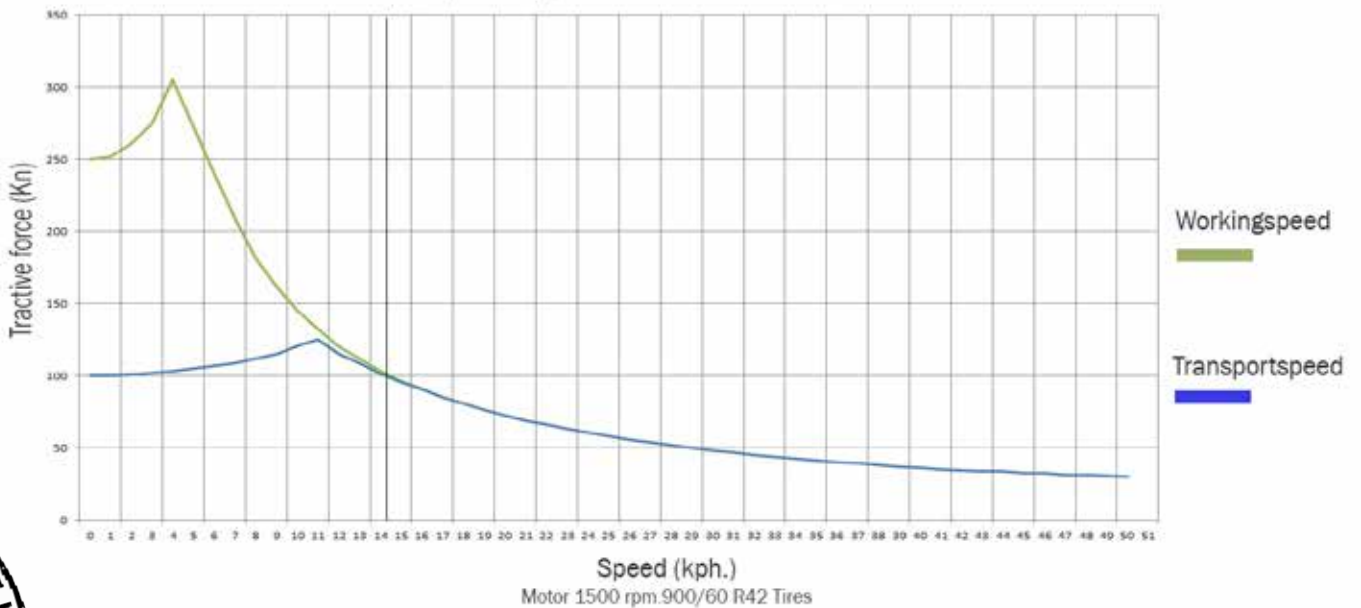



# MACHINE CONFIGURATIONS



## The Vredo Slurry System

The two axle VT7028-2 carries a lightweight polyester slurry tank of 21 m<sup>3</sup>, the three axle VT7028-3 carries a 32 m<sup>3</sup> liter tank or a 25m<sup>3</sup> + 7m<sup>3</sup> FlexTank and is capable to take a full trailer truck-load in one go. The pump-slicer unit is positioned at the front of the machine, which gives a perfect view from the cab of the reload operation from the pit, container or tanker. The 12.000 liter/min positive displacement slurry pump in combination with the 10 inch reloading arm enables maximum capacity and flexibility under all circumstances. The Vredo slicing filter in front of the pump makes sure that all larger particulates in the slurry are chopped or separated from the liquid slurry. To avoid damage to the pump and prevent the slurry injector hoses clogging up. The heavy duty 3 point steerable rear hitch with CAT 3N, 3 or 4N pickup hooks is capable of handling all kind of injectors on the market. The hitch is automatically steered in accordance with the crab steering.



Up to 36 meter  
dribble-bar applicator



Up to 30 meter  
sliding-shoe applicator

# MACHINE CONFIGURATIONS

## The Vredo Spreader

The VT7028's flat and long loading platform in both the two and three axle machine builds, is an excellent place for a dry manure/compost spreader system. The mounting points are standard equipped with load-cells between mounting points and body. This gives optimal spreader control and monitoring of the work being done. The 2 axle machine has a 18 m<sup>3</sup> or 25 tons spreader box, the 3 axle up to 27 m<sup>3</sup> or 35 tons.



## The Vredo Sugarbeet transportbox

Owing to the multi-purpose chassis design, the VT7028 is capable of working with all kinds of systems, e.g. transport boxes for all types of materials: sugar-beets, potatoes, grains, etc. Owing to the powerful hydraulic system for external use, every type of box can be supplied with the correct flow and pressure of oil.



## The Vredo Silage dozer

Thanks to its front mounted optional 3 point CAT 3 hitch system, the VT7028-2 is an ideal machine to be used as a silage dozer and compacter. The pump-cutter unit on the front and the tanksystem can be easily quickly removed in order to install the dozerblade and ballast weights. The VVT700 CVT transmission also makes the machine very useable as silo dozer.



## The Vredo VT7028 as tractor

Thanks to the fact that the axles and VVT700 CVT transmission are capable of handling 687HP and 2890Nm in continuous operation. The VT7028 is an excellent machine to be used for heavy pulling operations. The machine can be ballasted on the loading platform for the heaviest traction jobs. The all-round suspension and lockable cross and longitudinal differentials make sure that the power is transmitted without minimal slippage. Please contact us for more details concerning this special application.



# THE VT7028 CONCEPT

## CABIN

- Pneumatic suspended Claas cabin
- 2 x 7 inch Hydac Virtual Terminal
- Seat mounted operation console
- Ergonomic joy-sticks (2x)
- Grammer Maximo Super-Comfort seat
- Climatronic A/C
- Camera and LCD color monitor
- Passenger seat

## ENGINE

- Deutz TCD 16.0 V8
- 8 cylinder V-engine
- Displacement 16 liter
- Power 505 kW/687 HP
- Maximum torque 2890 Nm
- Emission Stage 4/Tier 4 Final

## LIGHTNING

- Roadlights Bi-LED
- LED workinglights on cab
- LED workinglights

## TYRES

- 900/60 R42 CHO
- 1250/50 R32
- 520/85 R42 + 380/90 R50  
Tramline tires for corn application





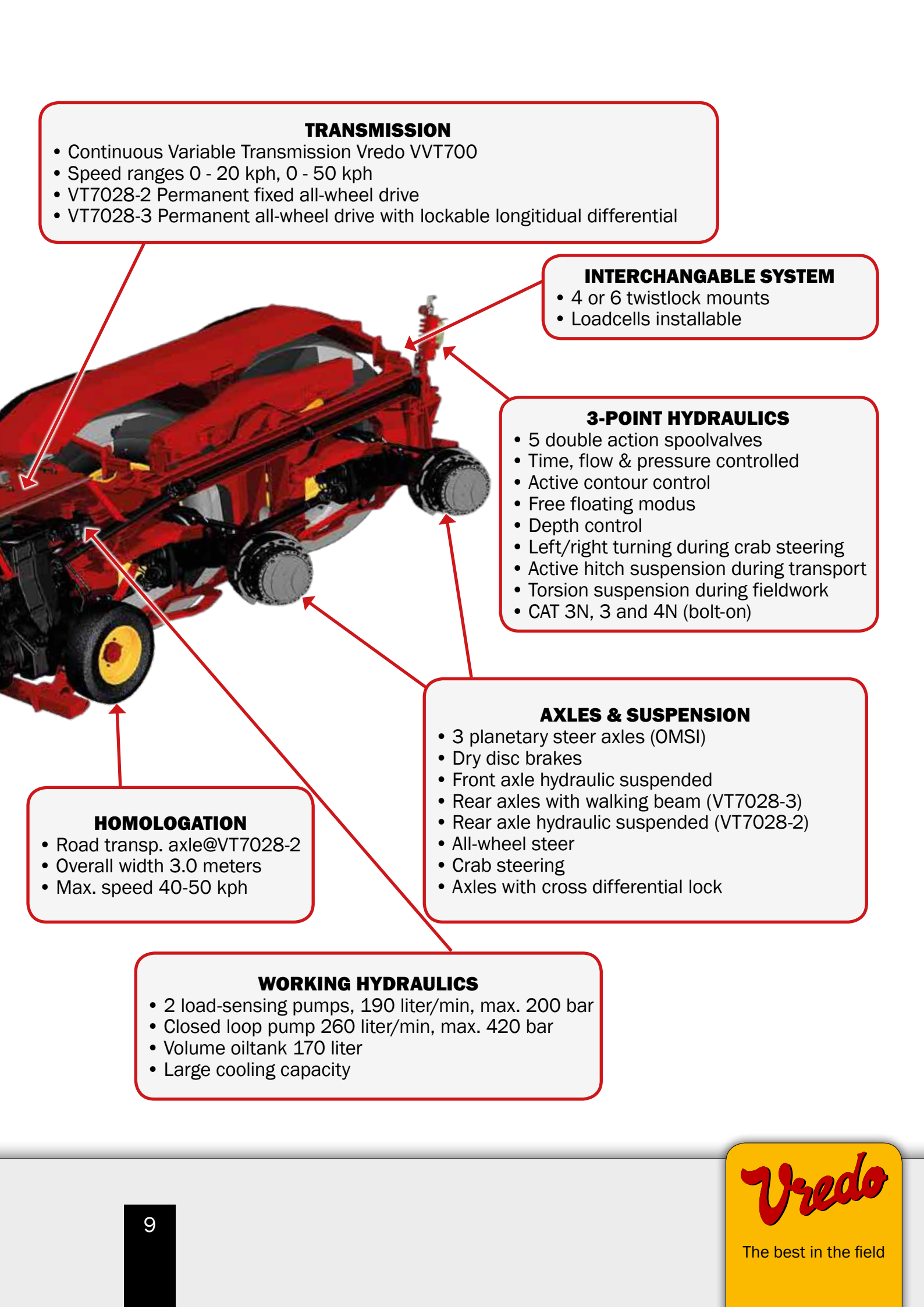

### TRANSMISSION

- Continuous Variable Transmission Vredo VVT700
- Speed ranges 0 - 20 kph, 0 - 50 kph
- VT7028-2 Permanent fixed all-wheel drive
- VT7028-3 Permanent all-wheel drive with lockable longitudinal differential

### INTERCHANGABLE SYSTEM

- 4 or 6 twistlock mounts
- Loadcells installable

### 3-POINT HYDRAULICS

- 5 double action spoolvalves
- Time, flow & pressure controlled
- Active contour control
- Free floating modus
- Depth control
- Left/right turning during crab steering
- Active hitch suspension during transport
- Torsion suspension during fieldwork
- CAT 3N, 3 and 4N (bolt-on)

### AXLES & SUSPENSION

- 3 planetary steer axles (OMSI)
- Dry disc brakes
- Front axle hydraulic suspended
- Rear axles with walking beam (VT7028-3)
- Rear axle hydraulic suspended (VT7028-2)
- All-wheel steer
- Crab steering
- Axles with cross differential lock

### HOMOLOGATION

- Road transp. axle@VT7028-2
- Overall width 3.0 meters
- Max. speed 40-50 kph

### WORKING HYDRAULICS

- 2 load-sensing pumps, 190 liter/min, max. 200 bar
- Closed loop pump 260 liter/min, max. 420 bar
- Volume oiltank 170 liter
- Large cooling capacity

# ENGINE VT7028

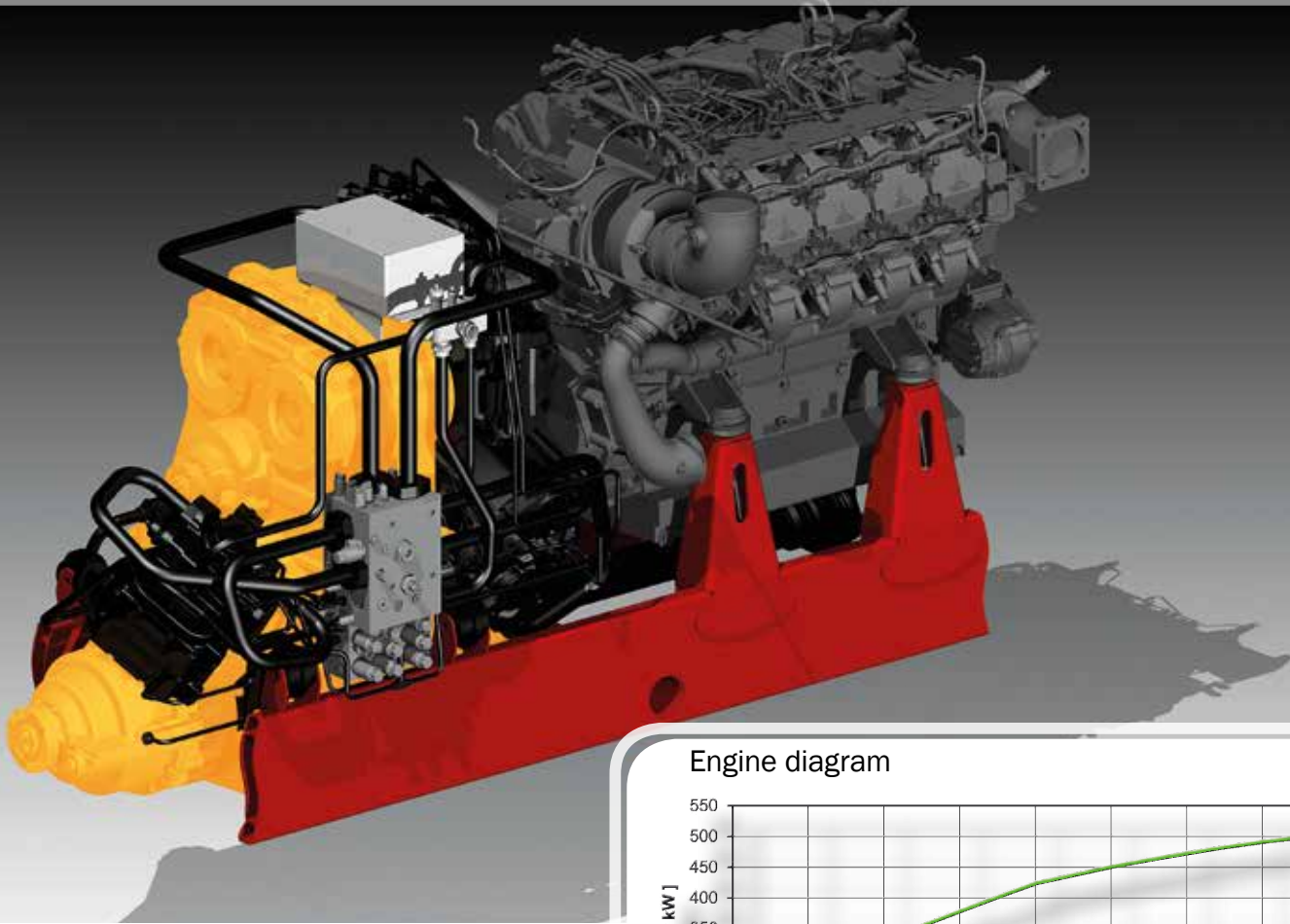

## Engine

The Deutz TCD 16.0 V8 engine has a very compact design in 90 degrees V version. The engine built according to Stage 4/Tier 4 Final emission specification has a modular exhaust after treatment system (EAT) with SCR technology. The powerful Common Rail injection system and the electronic engine control(EMR4) with intelligent link to the VVT700 CVT transmission control, ensure optimum engine performance at low fuel consumption.

Engine diagram

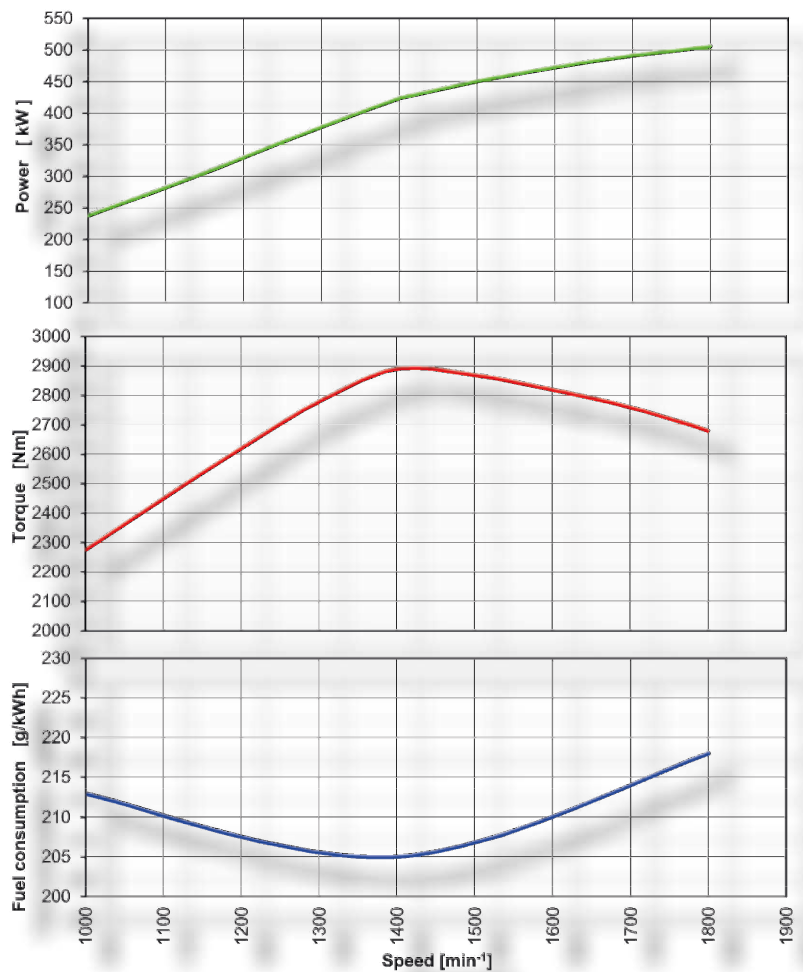



## Transmission

The VVT700 CVT transmission is built out of two main parts: the mechanical gearbox with planetary gearssets and couplings and the standard hydrostatic pump and motors, which are not integrated in the gearbox but mounted on the outside of the casing. The variable hydrostatic pump of 300 cm<sup>3</sup> and motors(2) for controlling the powersplit have a displacement of 233 cm<sup>3</sup>. There are two speed ranges: 0-20km/h and 0-50km/h. The transmission also has a optional shiftable mechanical PTO , capable for full engine power. Three pump pads for external hydraulics pumps. A permanent front and rearwheel drive with longitudinal differential with a shiftable lock.



## Axles

The VREDO dedicated designed heavy duty OMSI steer axles are capable to carry full load up to 50kph. The axles have planetary final drives and external disc brakes, with full hydraulic suspension(VT7028-2).

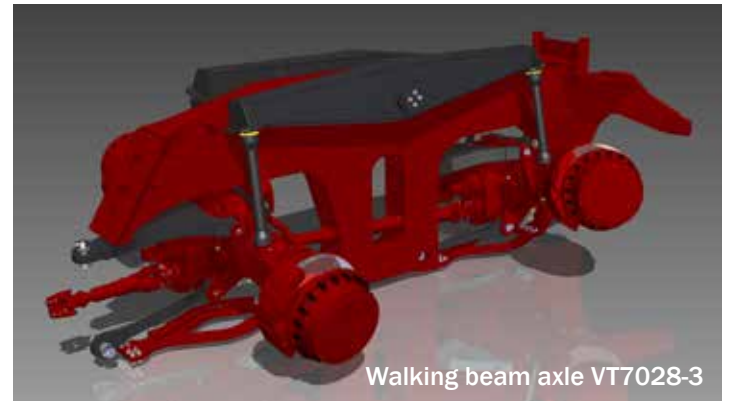
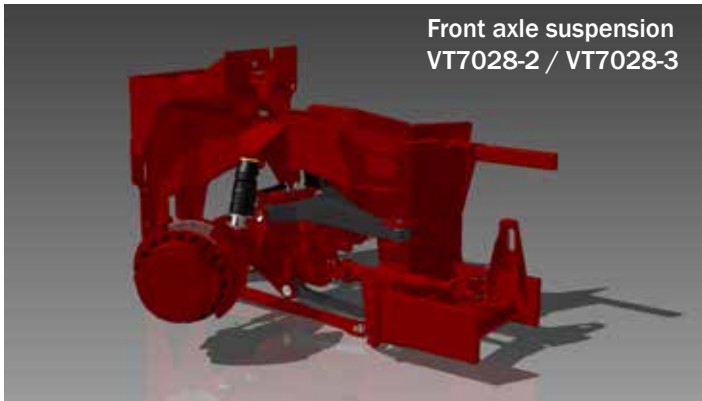

## STEERING & WEIGHT DISTRIBUTION

### Crab steering

The serial crab steering enables the machine to drive with all four tires along each other, for minimal ground compaction to save the soil. Also the four and six wheel steer gives the machine an excellent manoeuvrability on the farm, during transport and in the field.

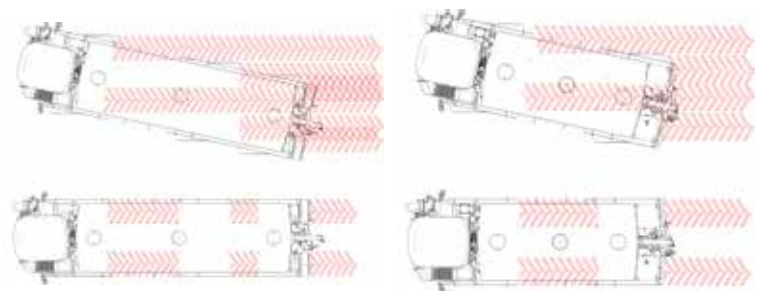

### GPS steering

The optional GPS steering on a Vredo Trac is standard a Trimble or John Deere steering system. Because it is completely integrated, it functions perfectly in combination with crab steering.

## Perfect weight distribution

The machine is designed for an optimum weight distribution over front and rear axle, so that the lowest possible tyre inflation pressure can be used on all four or six wheels.

The cab is also placed far to the front so that the implement systems can be optimally positioned.



50%

50%

## OPERATOR'S CAB

The spacious all around suspended comfort cab on the VT7028 is an optimum working place for long working days. It provides the operator with a safe, quiet and comfortable working area. The huge glass area offers superb visibility and comfort is further enhanced by climate control air conditioning and the super-comfort airsuspended seat.

From the seat mounted operation console all functions can be activated in a very ergonomic sense. Two joysticks in close proximity to each other gives excellent ease of operation. The 2 x 7 inch full color terminals show all required operator information of vehicle and implement system in an accurate way.

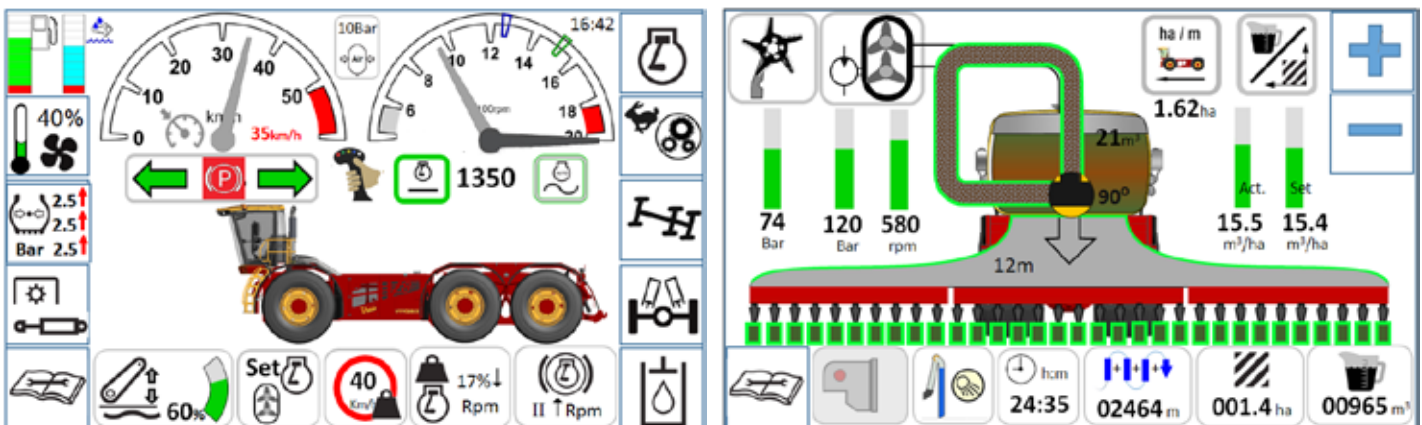

## FEATURES & OPTIONS

FEATURES



Crab steer and Vredo are an obvious combination



A 135° rotatable and telescopic reload arm gives great docking flexibility



Clean water tank for washing hands, and a handy storage box for PPE



FEATURES



6" female reload connector. At opening the pump starts automatically



Cooling system with reversible fan, easy to clean - maximum cooling capacity



Hitch with active implement suspension and auto-controlled in crab steering



Standard central automatic lubrication for maximum longevity



Around the clock application in "broad daylight"



Tippable tank for easy access during maintenance



Slicing filter with automatic ejection function, operated from the cab



Electronic controlled air conditioning, seat comfort, etc., offers the highest level of comfort



Easy entry into the fully air suspended cab.

OPTIONS



7m3 pumpable liquid bag on top of 25m3 polyester tank. (FlexTank)



Row-crop wheels for driving in between the corn rows



Extra long silo reload arm with centrifugal pump (Superload)



Extra fuel tanks, left/right, total 350 liters



Centrifugal pump for very short reload time, up to 16.000 liters/min



Tyre pressure control system for optimum tyre pressure on the road and in the field

# SPECIFICATIONS

	<b>Vredo VT7028</b>
<b>Engine</b>	<b>Deutz TCD 16.0 V8</b>
Cylinder	V-8
Displacement	15,98 litre
Nominal rpm	1800 rpm
Nominal power	505 kW / 687 HP
Maximum Torque	2890 Nm @ ≈ 1400 rpm
Emission stage	Stage 4 / Tier 4 Final
Volume tank (fuel   AdBlue)	650 litre   85 litre   ( optional fuel tank 350 liter )
<b>Transmission</b>	<b>Vredo VVT700 CVT / Vario</b>
Speed	Forward 0-20kph, 0-50kph, Stepless
	Rearward 0-15kph, Stepless
All wheel drive	Permanent with lockable diff. at the VT7028-3
	Permanent fixed at the VT7028-2
<b>Chassis</b>	<b>Welded chassis (high tensile steel)</b>
Variants	Standard chassis with 1-axle option at the back
	Standard chassis with 2-axle option at the back
<b>Axles</b>	<b>OMSI steer axles</b>
Differential axle lock	Front- and rear axle(s) shiftable
Axle suspension	Frontaxle hydraulic suspension
	Rearaxle hydraulic suspension(2 axle)
	Rearaxle walking beam (3 axle)
Steering functions	Front axle steer / All wheel steer / Crab steering left and right
<b>Brakes</b>	<b>Knott</b>
Service brake	Dry disc brake, hydraulically activated
Parking brake	Spring-loaded dry disc brake on transmission output to front axle
<b>Tyres</b>	
	900/60 R42 CH0 standard
	1250/50 R32
	520/85 R42 + 380/90 R50 Double row-crop wheels
<b>Working hydraulics</b>	<b>SauerDanfoss</b>
Load-sensing, max flow and pressure	2x 190 L /min at max. 200 bar
External hydraulic valves	4 double-acting valves
Closed loop maximum flow and pressure	260 L/min at max. 420 bar
Volume hydraulic oiltank	170 liter
<b>3 Point Hitch</b>	
Category	CAT 3N, 3 and 4N
Hitch travel	660mm, max height 1000 mm@900/60 R42 Tires
Lifting force	75kN continuously up to 105 kN
Functions	Active controlled pressure/release system   Free-floating   Depth control



# SPECIFICATIONS

Steerable	Left/Right crabsteer controlled
Suspension	Active transportmode
	Torsion suspension during fieldwork
External operation	Switch on fender, left and right
<b>Cabin</b>	<b>Claas</b>
Suspension	All round pneumatic suspension
Seating	Air-suspension Grammer Maximo Super-Comfortseat   Passenger's seat
Airconditioning	Climatronic
Mirrors	Electrical adjustable and heatable mirrors
Operation	Console with joysticks and ISOBUS terminal installed on driverseat
	Camera and LCD colormonitor, radio/CD player with Bluetooth
<b>Lighting</b>	
Road lights	4 x Bi-LED
Working lights on frontside cab	6xLED
Working lights backside vehicle	4XLED + 2xLED on system
Rotating beacon	2x on cab, 1x on rear
<b>Slurry system</b>	
Pump-slicer unit	12.000 liter Vogelsang positive displacement pump
Slicing-filter	Vredo FT 6200
Reload-arm	10 inch, 135 deg. turn angle
Rate control	Over Terminal, speed controlled, speed independant
Polyester tank	VT7028-2: 21m <sup>3</sup> , VT7028-3: 32m <sup>3</sup> and 25m <sup>3</sup> +7 m <sup>3</sup> , FlexTank
<b>Dimensions</b>	
Overall length 2 axle machine	8,60 m
Overall length 3 axle machine	11,10 m
Overall width	3,00 m
Height (on 900 tires)	4,00 m
Bottom clearance (on 900 tires)	0,50 m
Wheelbase (2 axle)	4,80 m
Wheelbase (3 axle)	4,80 m + 2,50 m
Turning circle (outside diameter) (2 axle)	14,30 m
Turning circle (outside diameter) (3 axle)	19,20 m
<b>Total empty weight</b>	
Total weight 2 axle ( standard slurry machine )	empty 21.500 kg   21m <sup>3</sup> tank
Total weight 3 axle ( standard slurry machine )	empty 26.200 kg   32m <sup>3</sup> tank
Total weight 3 axle ( FlexTank )	empty 28.500 kg   25m <sup>3</sup> +7m <sup>3</sup> FlexTank
<b>Serial specification</b>	
	Automatic central greasing
<b>Options</b>	
	Central Tire Inflation System with automatic control   GPS Steering System Trimble or JD   NIR-Sensor   Extra road transport axle   Front 3 point hitch   Telescopic loading arm  Further options on request
Vredo Dodewaard BV reserves the right to change specification and design of products described in this literature without notice.	

# Service team



## Our philosophy

Vredo's philosophy is "Built to Work": And yet, every machine, however reliable, needs regular maintenance to keep working. To make the maintenance work as easy as possible, we've designed our machines to be as service-friendly as possible. Vredo's support on parts and service is customer-focussed, reliable, competent and fast.

## Spare Parts

Vredo maintains good stock level on most own-parts (incl. wear parts). When you purchase an original Vredo part, you purchase quality and assurance of mind. Our parts are manufactured to rigorous guidelines which meet our high standards.

## Service

Vredo has a full-time team of professional and well-trained service engineers in house in order to make sure that your machine continues to function optimally, even during the most hectic peak-periods. Thanks to our fleet of service vehicles, we are also able to attend to repairs and servicing on location, wherever our client may be in the world. The Vredo Service team also functions as a back up for the dealer Service Teams, with frequent updates and organised trainingdays.



## Colophon

### Published by:

Vredo Dodewaard BV  
Welyestraat 25a  
6669 DJ DODEWAARD  
Nederland

T: +31 488 411254  
F: +31 488 412471  
E: sales@vredo.com  
W: www.vredo.com

*Would you like to lease a Vredo ?  
Ask your representative  
for the options.*

Copyright © 2018 Vredo Dodewaard BV. All rights reserved. All product information is correct at time of printing.

Dealer stamp/stempel/Stempel/tampon concessionnaire

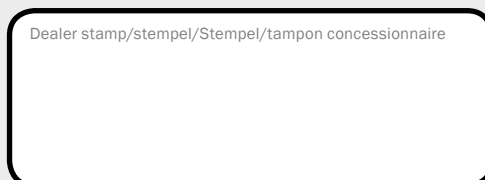

The best in the field